

PLAN

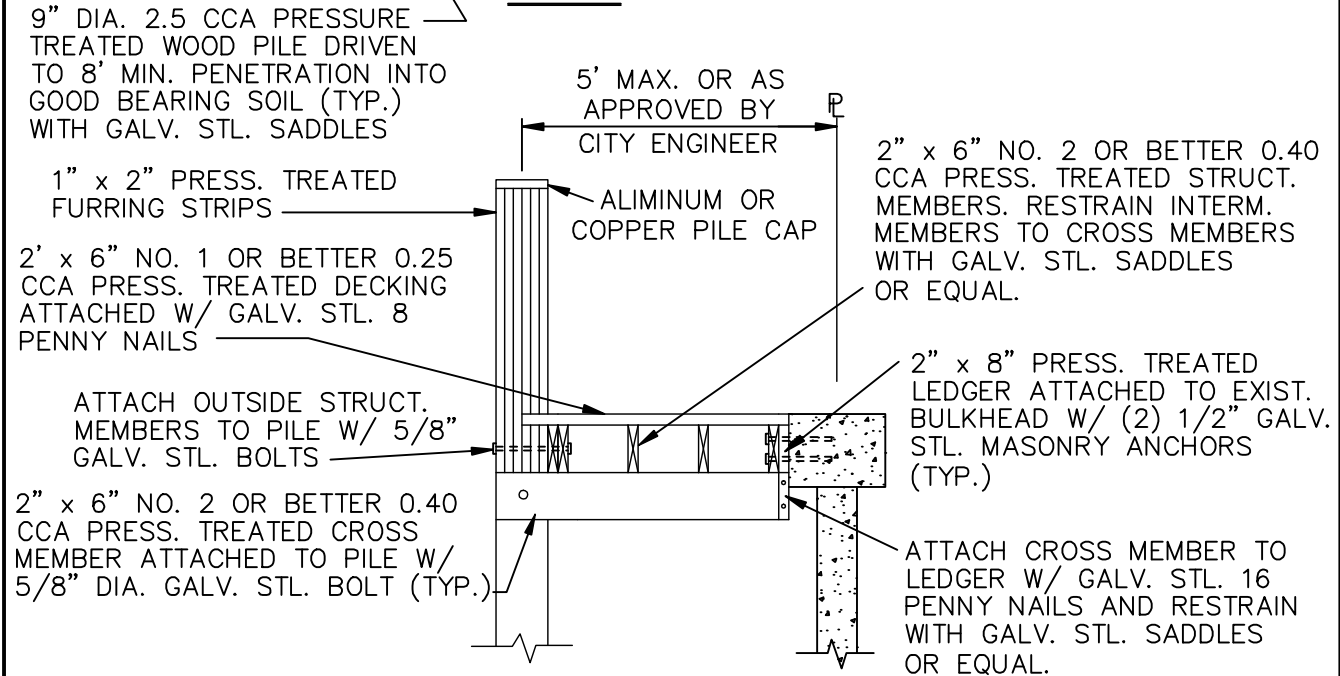

SECTION A-A

STANDARD DOCK PLAN

REVISIONS		ENGINEERING DEPARTMENT CITY OF POMPANO BEACH	STANDARD DOCK PLAN	
BY	DATE		APPROVED BY:	DATE: FEB. 1998
		SCALE: N.T.S.	CITY ENGINEER	DWG. NO.
				307-1